

SPARE PARTS SECTION

HYDRAULIC PRESS

Model. HP-45P

Order Code P147

Edition No : HP-45-1

Date of Issue : 04/2020

The following section covers the spare parts diagrams and lists that were current at the time this manual was originally printed. Due to continuous improvements of the machine, changes may be made at any time without notification.

HOW TO ORDER SPARE PARTS

1. Have your machines **model number, serial number & date of manufacture** on hand, these can be found on the specification plate mounted on the machine
2. A scanned copy of your parts list/diagram with required spare part/s identified
3. Go to www.machineryhouse.com.au/contactus and fill out the enquiry form attaching a copy of scanned parts list.

CONTENTS

Pump Spare Parts Diagram.....	18
Pump Spare Parts List.....	19
Ram Spare Parts Diagram.....	20
Ram Spare Parts List.....	21
Press Spare Parts Diagram.....	22
Press Spare Parts List.....	23

HP-45P PUMP SPARE PARTS DIAGRAM

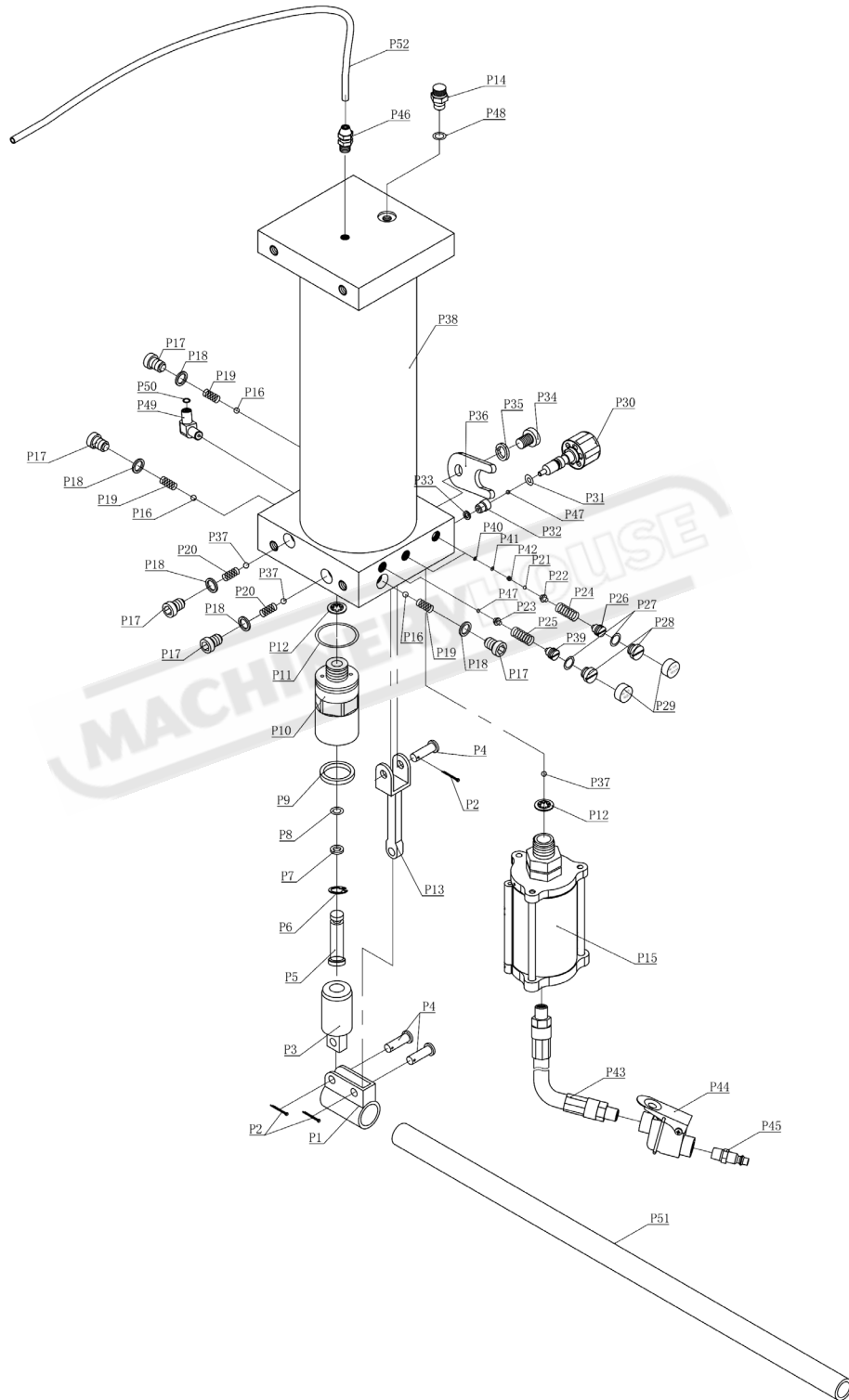

HP-45P PUMP SPARE PARTS LIST

No.	Description	Qty	No.	Description	Qty
P1	Socket	1	P27	O-ring	3
P2	Pin	2	P28	Screw	3
P3	Big pump core	1	P29	Cap	3
P4	Pin	3	P30	Release valve assy	1
P5	Small pump core assy	1	P31	O-ring	1
P6	Retaining ring	1	P32	Release valve seat	1
P7	PTFE washer	1	P33	Washer	1
P8	O-ring	1	P34	Screw	1
P9	U-ring	1	P35	Locking washer	1
P10	Pump core seat	1	P36	U limit	1
P11	O-ring	1	P37	Steel ball	3
P12	Copper washer	2	P38	Pump assy	1
P13	Connector bar	1	P39	Screw	1
P14	Screw assy	1	P40	Copper washer	2
P15	Air pump	1	P41	Washer	2
P16	Steel ball	3	P42	Screw	2
P17	Screw	5	P43	Air hose assy	1
P18	Washer	5	P44	Air valve assy	1
P19	Spring	3	P45	Connector	1
P20	Spring	2	P46	Connector	1
P21	Valve ball	2	P47	Steel ball	2
P22	Steel ball seat	2	P48	Nylon washer	1
P23	Steel ball seat	1	P49	Connector	1
P24	Spring	2	P50	O-ring	1
P25	Spring	1	P51	Handle	1
P26	Screw	2	P52	Oil hose	1

HP-45P RAM SPARE PARTS DIAGRAM

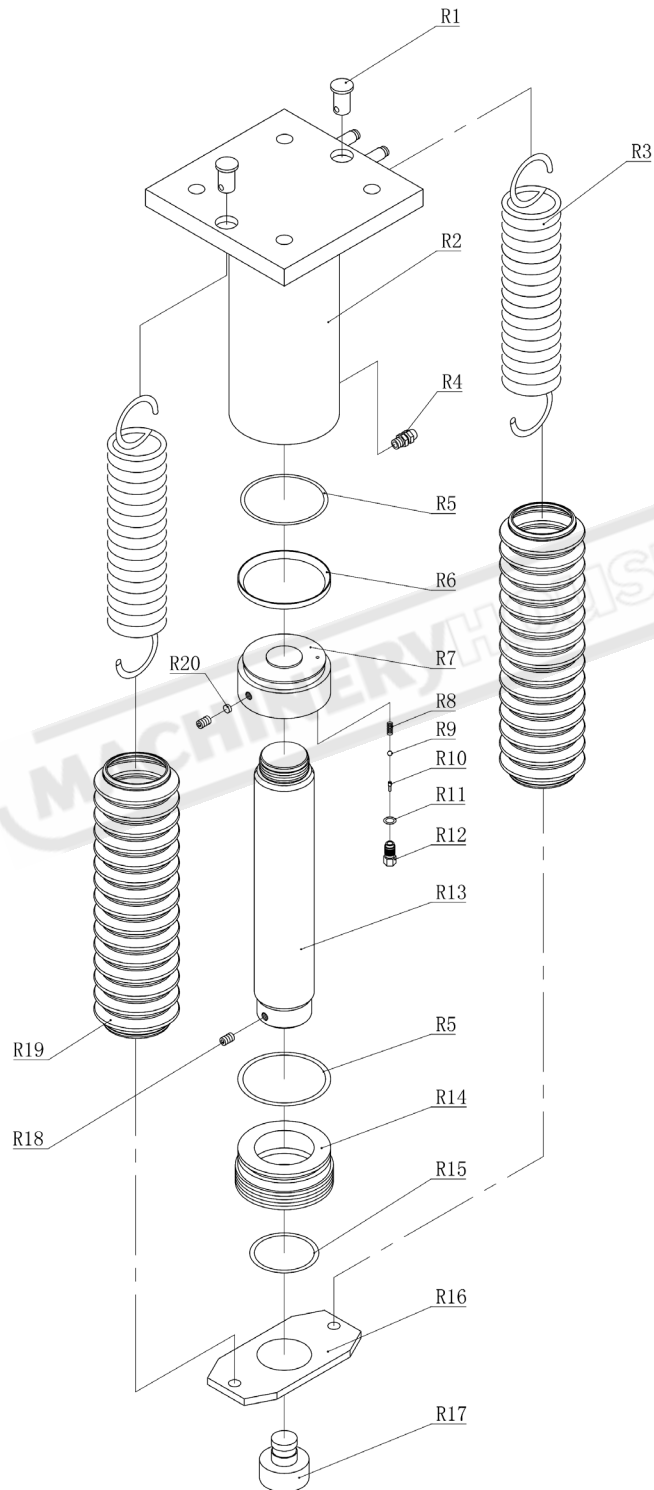

HP-45P RAM SPARE PARTS LIST

No.	Description	Qty	No.	Description	Qty
R1	Pin	2	R11	Nylon washer	1
R2	Ram	1	R12	Limit screw	1
R3	Spring	2	R13	Piston rod	1
R4	Connector	1	R14	Cylinder cover	1
R5	O-ring	2	R15	O-ring	1
R6	Washer	1	R16	Plate	1
R7	Piston saddle	1	R17	Saddle	1
R8	Spring	1	R18	Screw	2
R9	Steel ball	1	R19	Protection cover	2
R10	Screw core	1	R20	Nylon block	1

MACHINERYHOUSE

HP-45P PRESS SPARE PARTS DIAGRAM

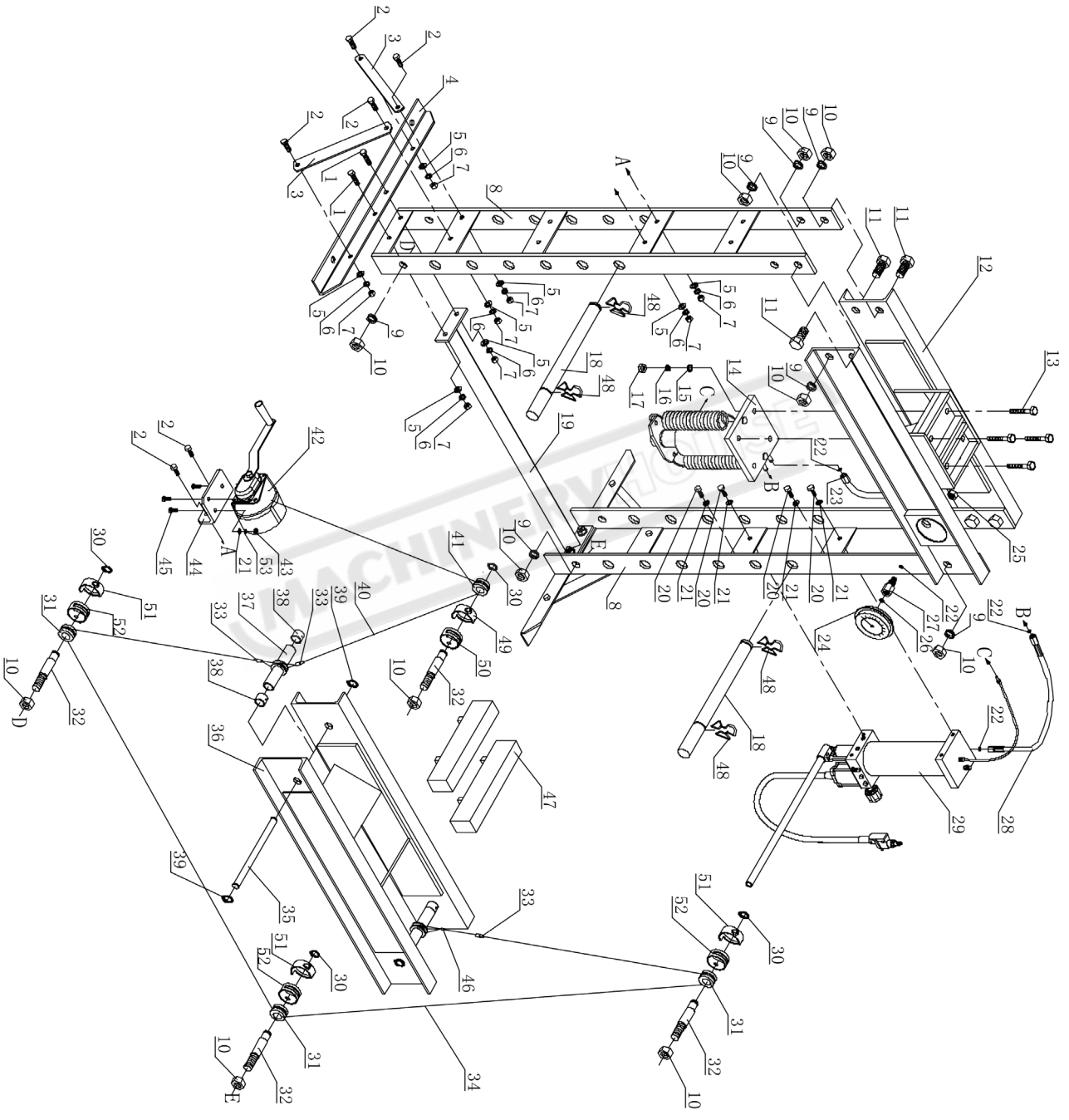

HP-45P PRESS SPARE PARTS LIST

No.	Description	Qty	No.	Description	Qty
1	Bolt	4	28	Oil hose 2	1
2	Bolt	10	29	Pump	1
3	Support	4	30	Retain ring	4
4	Base section	2	31	Small roller	3
5	Washer	14	32	Bolt	4
6	Locking washer	14	33	Sleeve	3
7	Nut	14	34	Cable	1
8	Post	2	35	Down beam	2
9	Locking washer	10	36	Down frame assy	1
10	Nut	14	37	Sleeve assy	2
11	Bolt	6	38	Sleeve 2	4
12	Upper beam	1	39	Retain ring	4
13	Bolt	4	40	Steel wire rope	1
14	Cylinder	1	41	Big roller	1
15	Washer	4	42	Winch	1
16	Locking washer	4	43	Nut	3
17	Nut	4	44	Fixed plate	1
18	Pin	2	45	Bolt	3
19	Base section bar	1	46	Connector	3
20	Bolt	4	47	Blocks	2
21	Washer	7	48	Retain ring	4
22	O-ring	4	49	Protection cover 1	1
23	Oil hose 1	1	50	Protection cover 2	1
24	Gauge	1	51	Protection cover 3	3
25	Nut	1	52	Protection cover 4	3
26	Nylon washer	1	53	Lock washer	3
27	Connector	1			